

DESIGN EVOLUTION OF ANTENNA SYSTEMS FOR DTV MULTICHANNEL OPERATION

CCBE (Central Canada Broadcast Engineers)
Horseshoe Resort Barrie, Ontario
September 18th, 2009



TOPICS ON

- 1.- An Improved Constant Impedance Channel Combiner for UHF TV
- 2.- UHF CPOL/EPOL Panel antenna to ensure mobile-handheld reception

A New UHF CPol/EPol Antenna for Mobile/Handheld Broadcasting

- Future requirements:
 - Receiving good quality signals on handheld receptors
 - Transmitted at any possible channel across the UHF broadcast band, in combination with other DTV channels through the same antenna

HOW TO GUARANTEE THE HANDHELD RECEPTION

- Mobile reception needs guaranteeing in the field level at each location within the coverage area.
- Due to the mobility of the receptor, any linearly polarized signal may suffer from cancellation at certain places due to multipath propagation.
- The use of elliptically polarized signals minimizes these risks.



Cpol/Epol Antenna Design Requirements

- In order to build broadband EPol/CPol antenna systems, a new panel antenna has been designed.
- The intended working band 470-722MHz is a broad bandwidth (42%)
- Compared to a linearly polarized antenna, the circularly polarized panel must overcome the following:
 - a. Broadband VSWR difficulties due to cross-coupling between signals.
 - b. Minimizing broadband scalloping due to competing needs of VPOL and HPOL.
 - c. A more complicated Power Splitting system .

Possible design approaches: (Possibility One)



- Cross Dipoles:
 - Lack of equal back reflector illumination
 - Consequently poor Hpol/Vpol ratio
 - Relatively small bandwidth (below 12%)

(Based on RYMSA experience on FM panels)

Possible design approaches (Possibility Two)

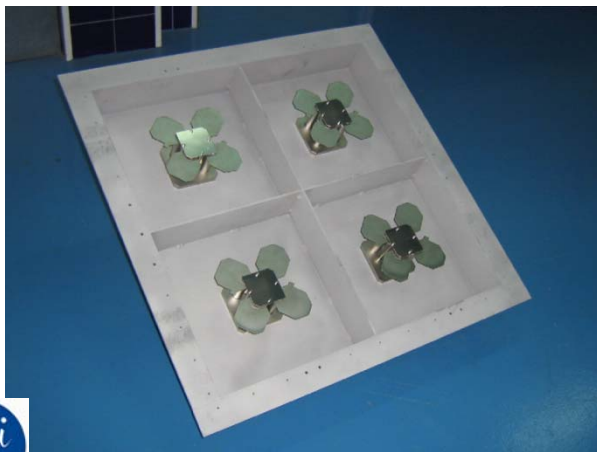

- Cavity:
 - Displays good Hpol/Vpol ratio
 - Not enough bandwidth to cover the intended frequency range with a single antenna.
 - Relatively small bandwidth (below 26%)

(Based on RYMSA experience on UHF cavity antennas for military applications)

Possible design approaches

Possibility Three-(Final)



- Parallel Dipoles:

- Competitive Hpol/Vpol ratio
- Adequate bandwidth

(This is the approach selected for the new design)

RYMSA-MCI EPol/CPol Antenna

- Primary radiation axes are vertical and horizontal.
- Single input with hybrid power divider on back panel allows the antenna to be CPol or EPol with varying levels of VPol

Electro-Mechanical Configuration

- Same radome as HPOL UHF panel.
- Internal stripline power distribution.
- Interchangeable back-panel hybrid/splitter.
- Single input: EIA 7/8 or DIN 7/16



Electro-mechanical Configuration

- Primary radiators and power splitting network

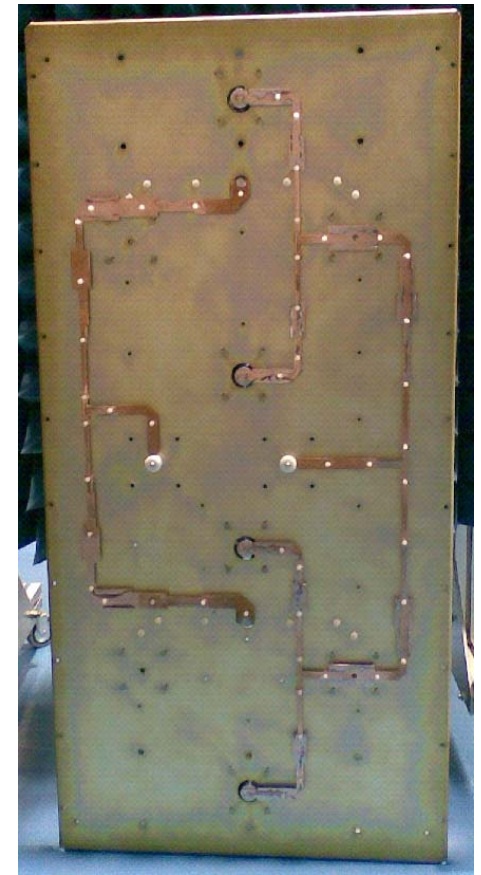

Electrical Specifications

- 470-722 MHz
- Polarization RHCP or RHEP
- VSWR ≤ 1.12
- Custom HPOL/VPOL ratios available
- 2.5 KW max average power
 - 1.25 KW max average per polarization.
- Axial ratio
 - Typical < 1.6 (4 dB)
 - Worst case ≤ 2.0 (6 dB) (> 700 MHz)
 - As measured on the horizon with 50/50 power distribution, HPOL/VPOL.

Radiation patterns tests vs design simulation

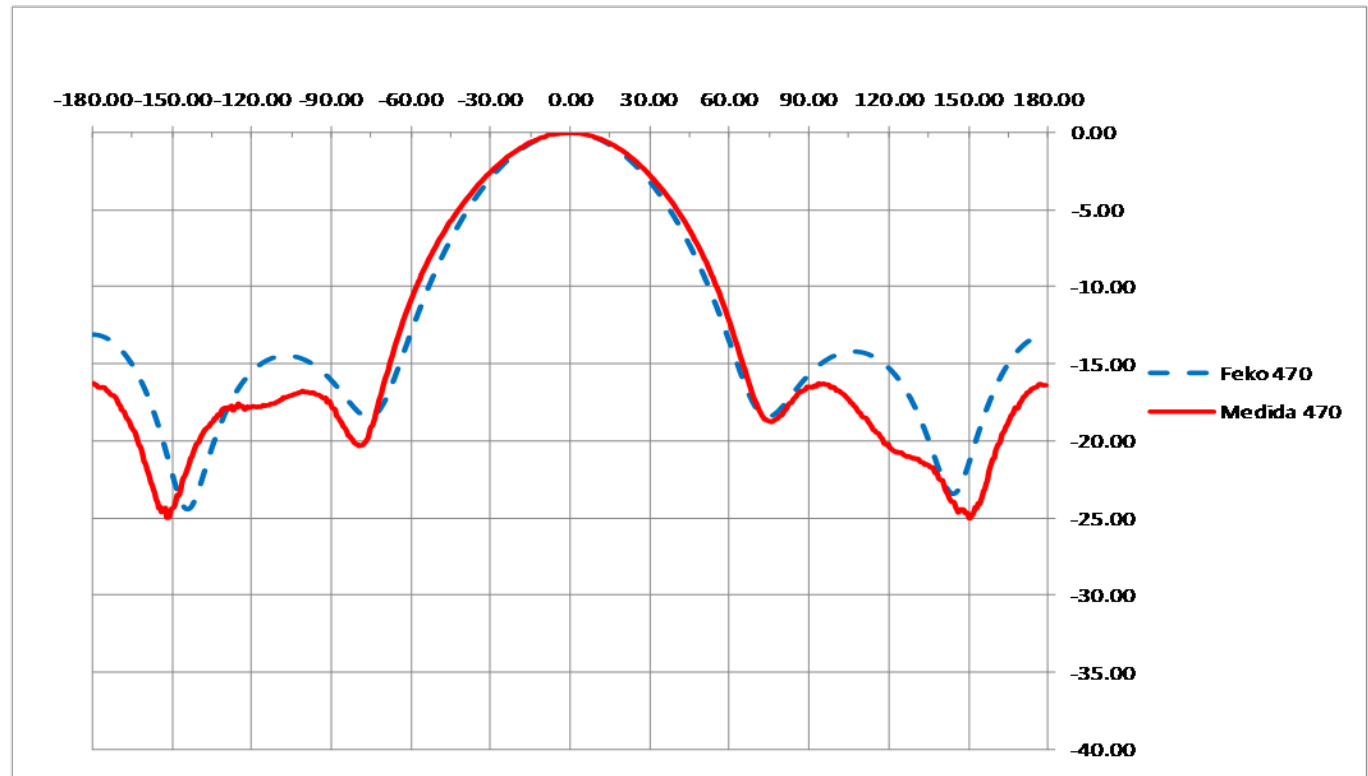

- HRP Hpol
- Freq. 470 MHz

Radiation patterns tests vs design simulation

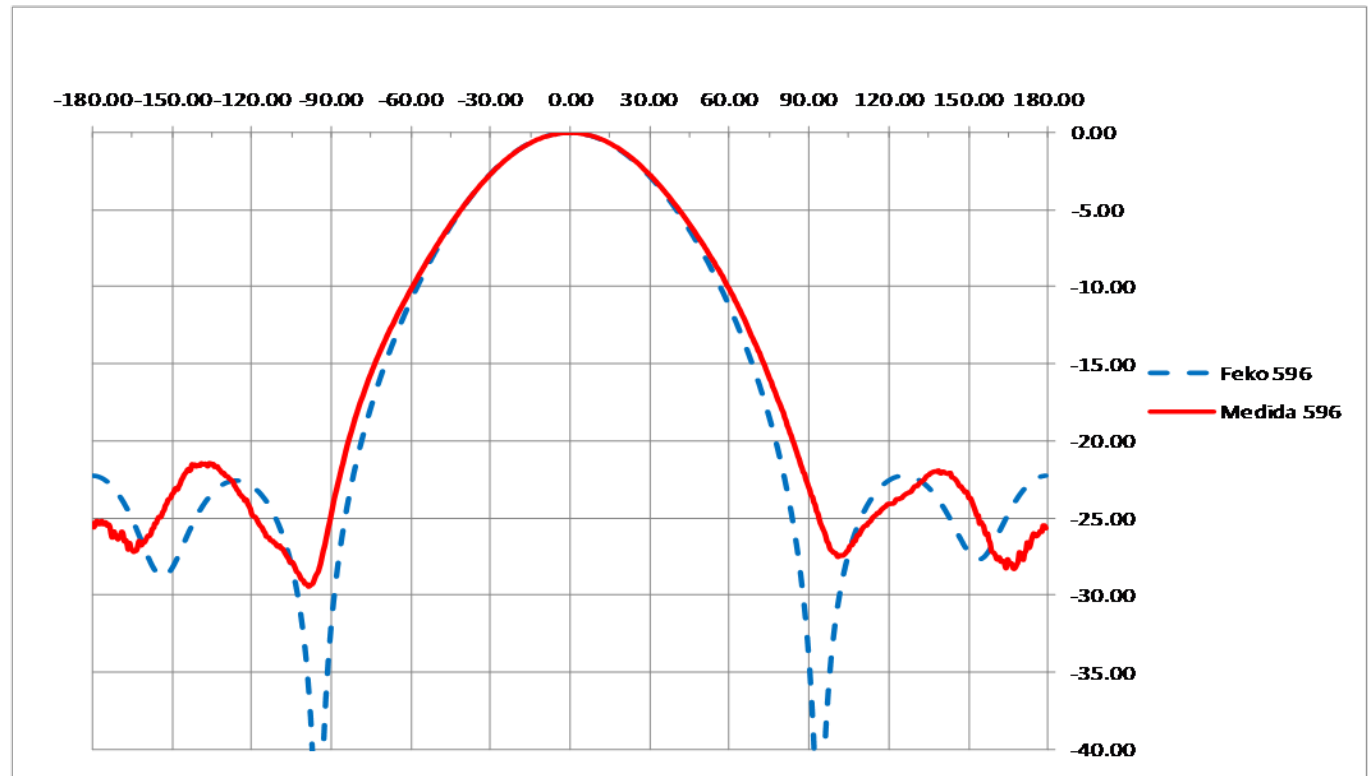

- HRP Hpol
- Freq. 596 MHz

Radiation patterns tests vs design simulation

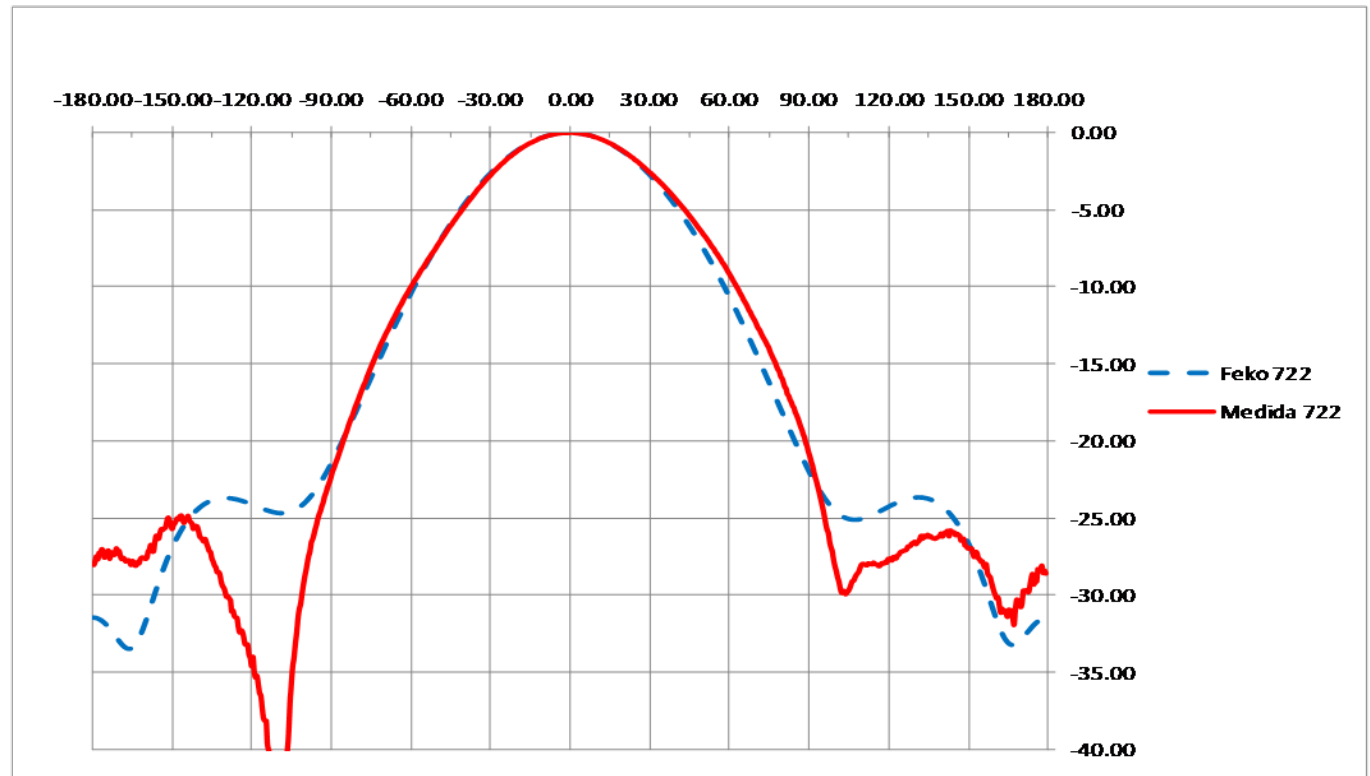

- HRP Hpol
- Freq. 722 MHz

Radiation patterns tests vs design simulation

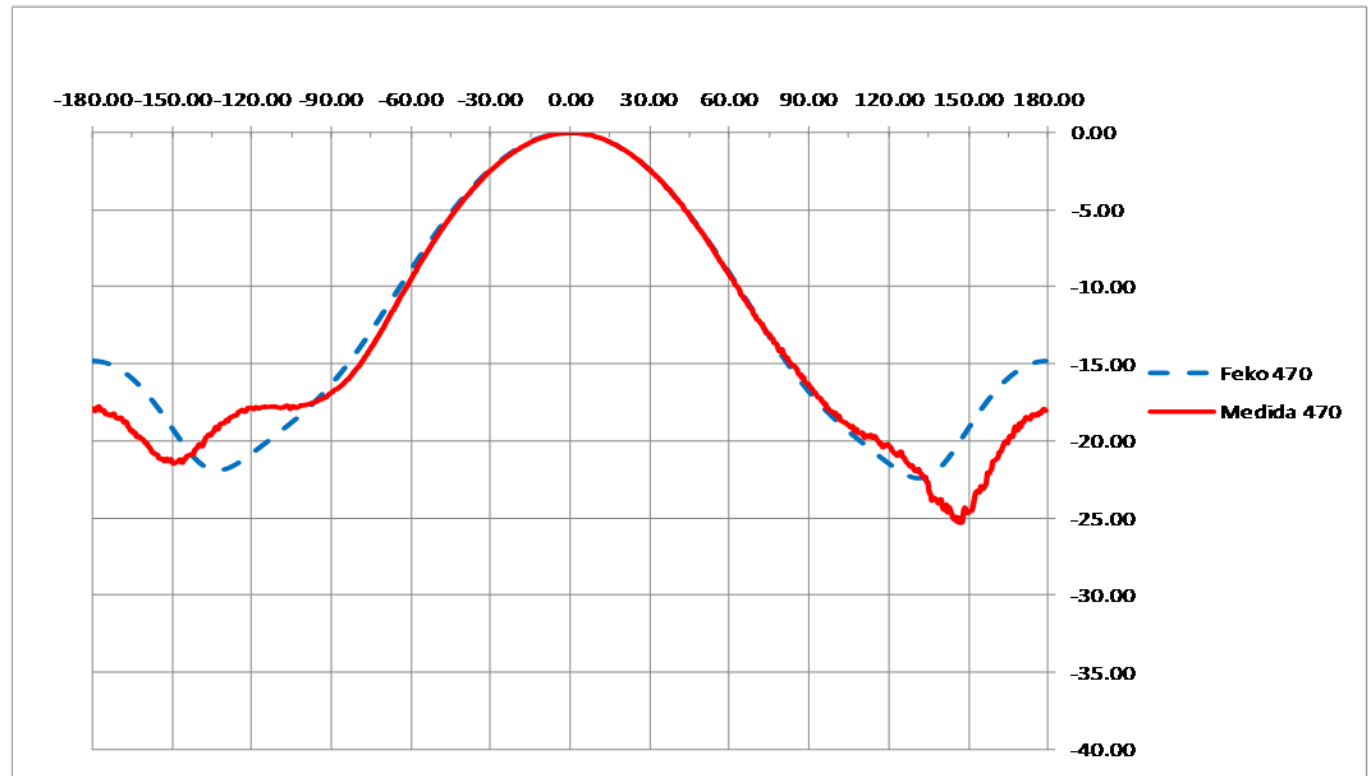

- HRP Vpol
- Freq. 470 MHz

Radiation patterns tests vs design simulation

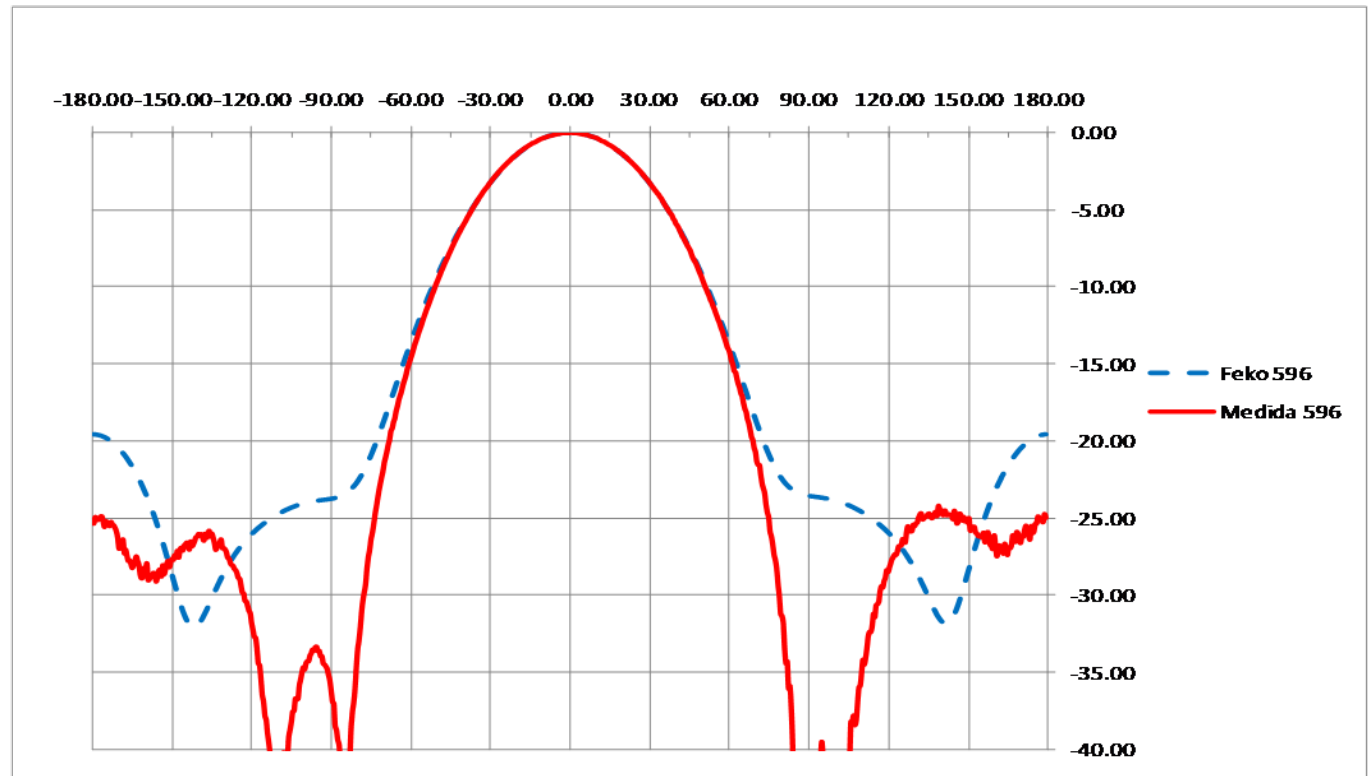

- HRP Vpol
- Freq. 596 MHz

Radiation patterns tests vs design simulation

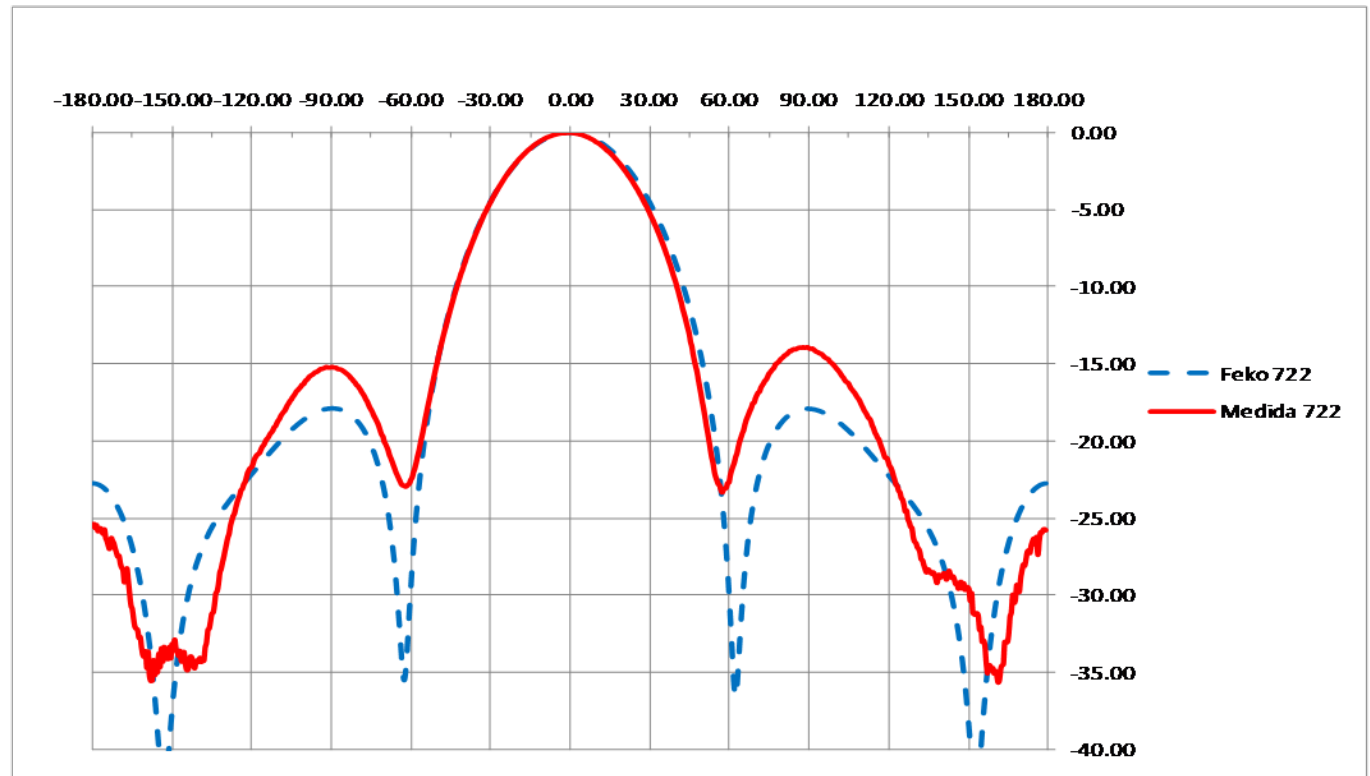

- HRP Vpol
- Freq. 722 MHz

Antenna system CPol Omni at 502 MHz

HPOL

- ± 2.3 dB scalloping

VPOL

- ± 1.1 dB scalloping

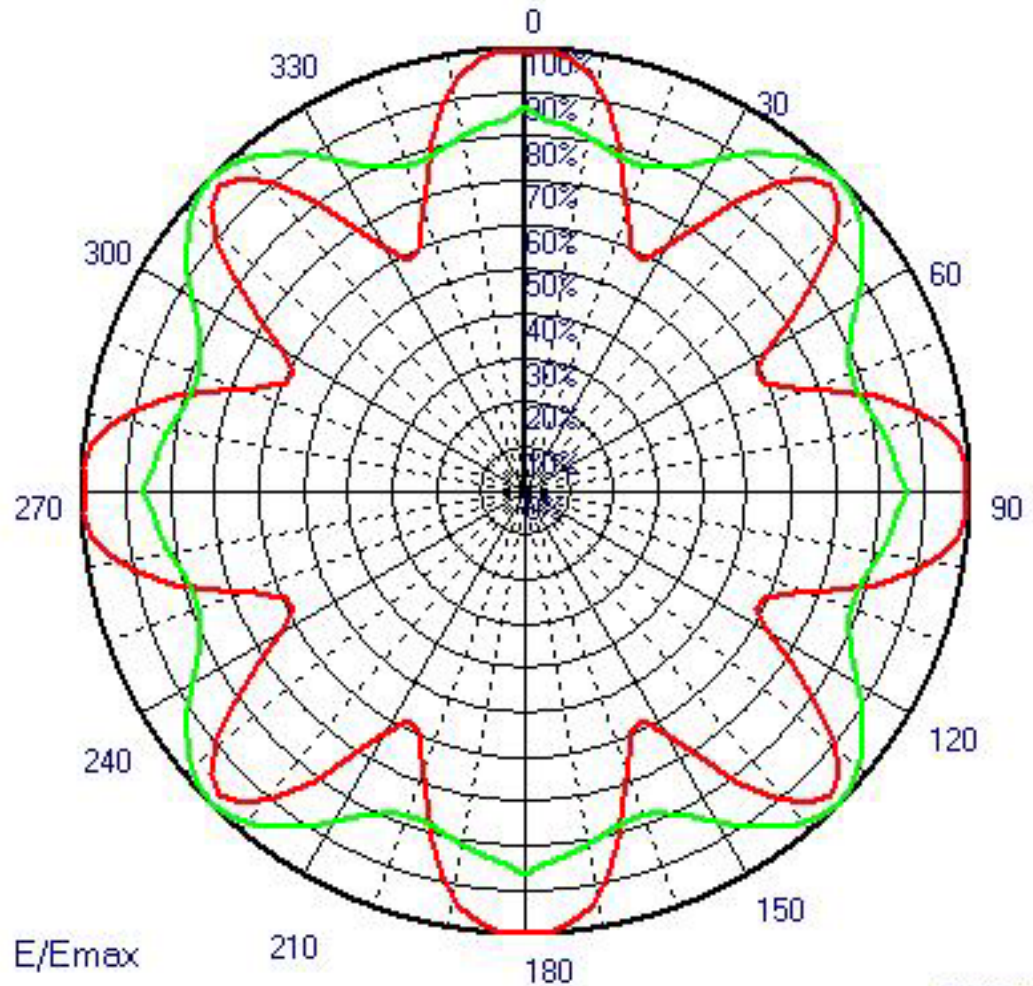

Antenna system CPol Omni at 564 MHz

HPOL

- ± 2.2 dB scalloping

VPOL

- ± 1.4 dB scalloping

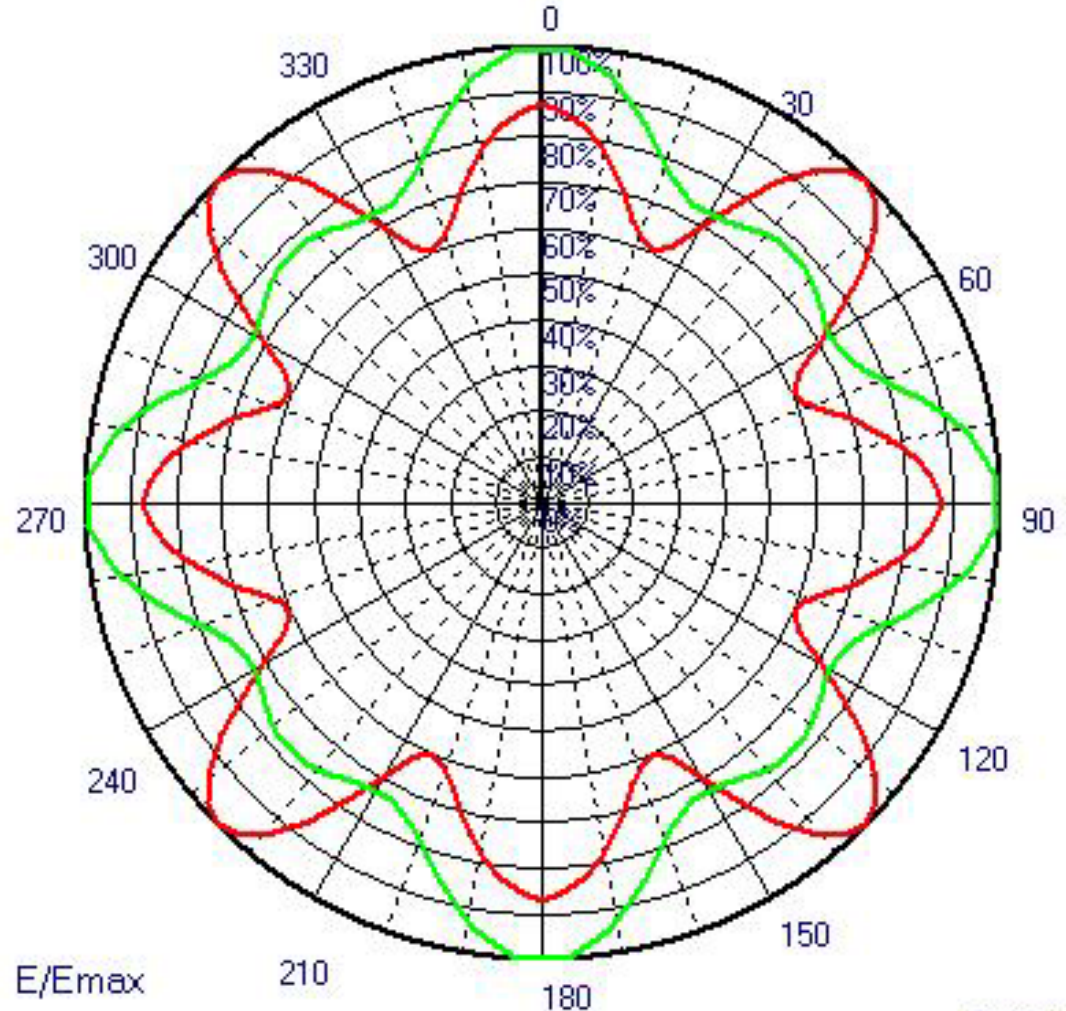

Antenna system CPol Omni at 596 MHz

HPOL

- ± 2.1 dB scalloping

VPOL

- ± 1.0 dB scalloping

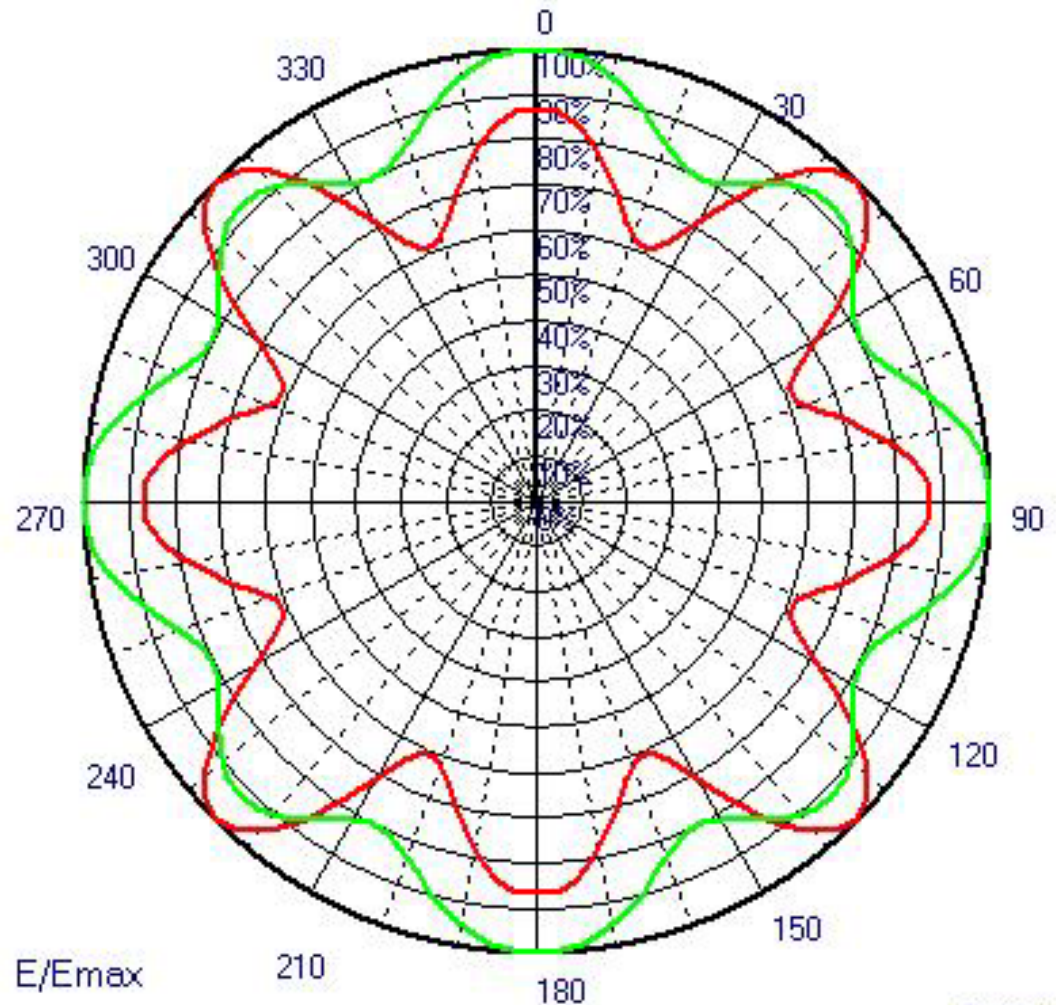

Antenna system CPol Omni at 628 MHz

HPOL

- ± 1.8 dB scalloping

VPOL

- ± 1.3 dB scalloping

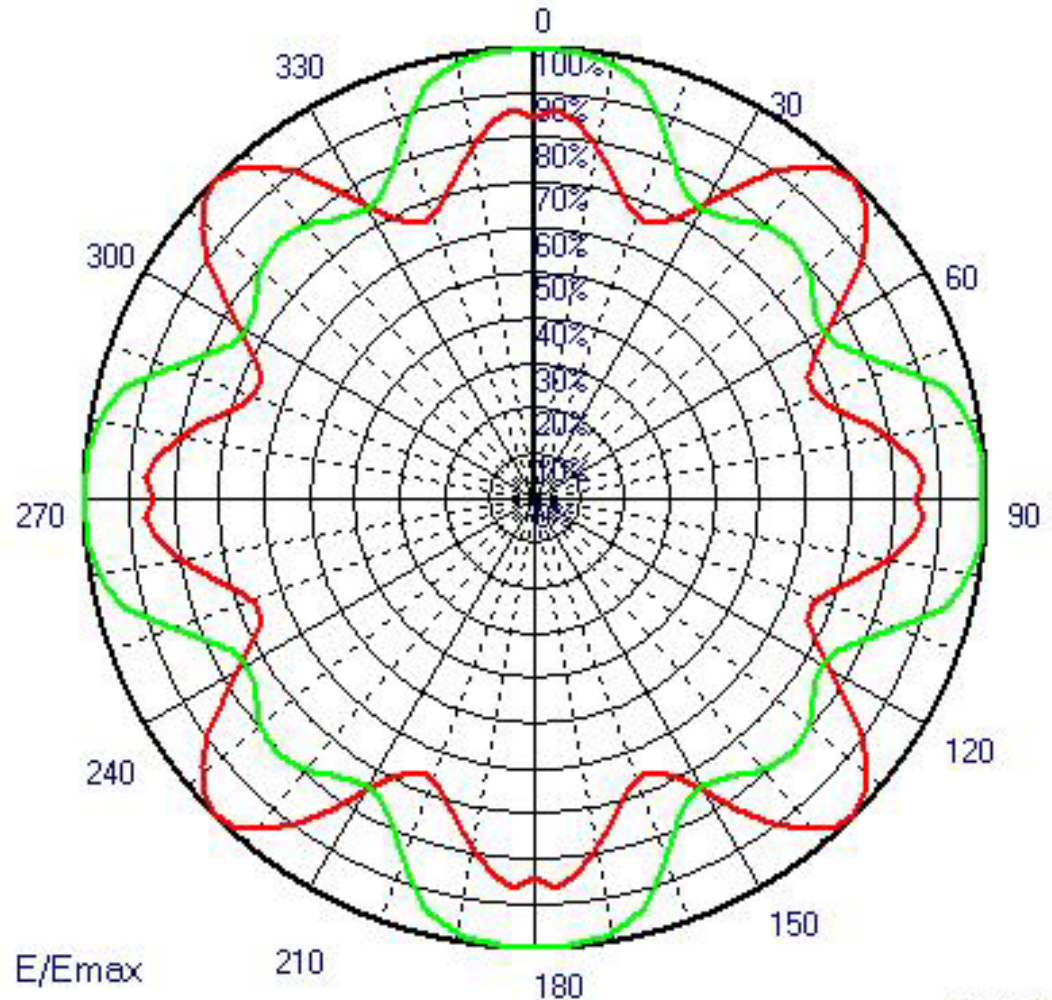

Antenna system CPol Omni at 690 MHz

HPOL

- ± 2.0 dB scalloping

VPOL

- ± 1.2 dB scalloping

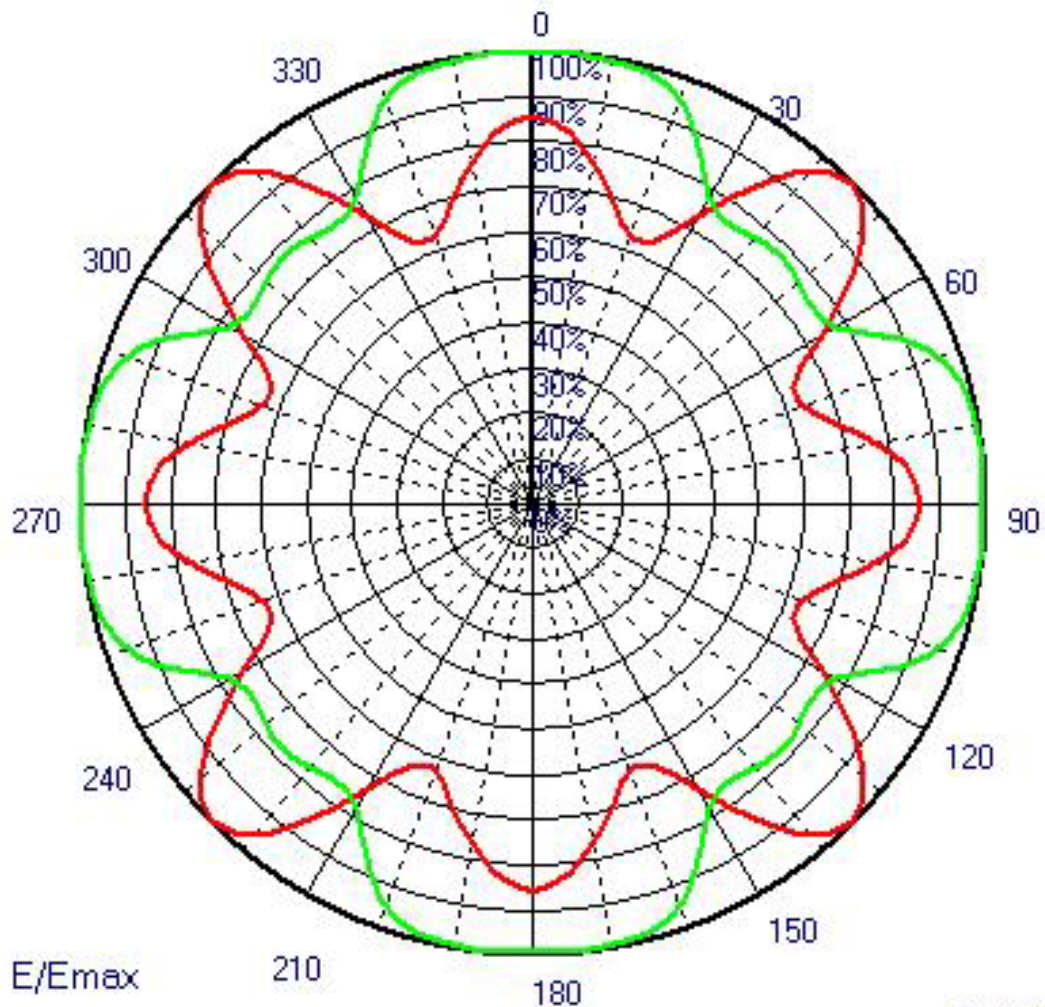

Antenna system CPol Omni at 722 MHz

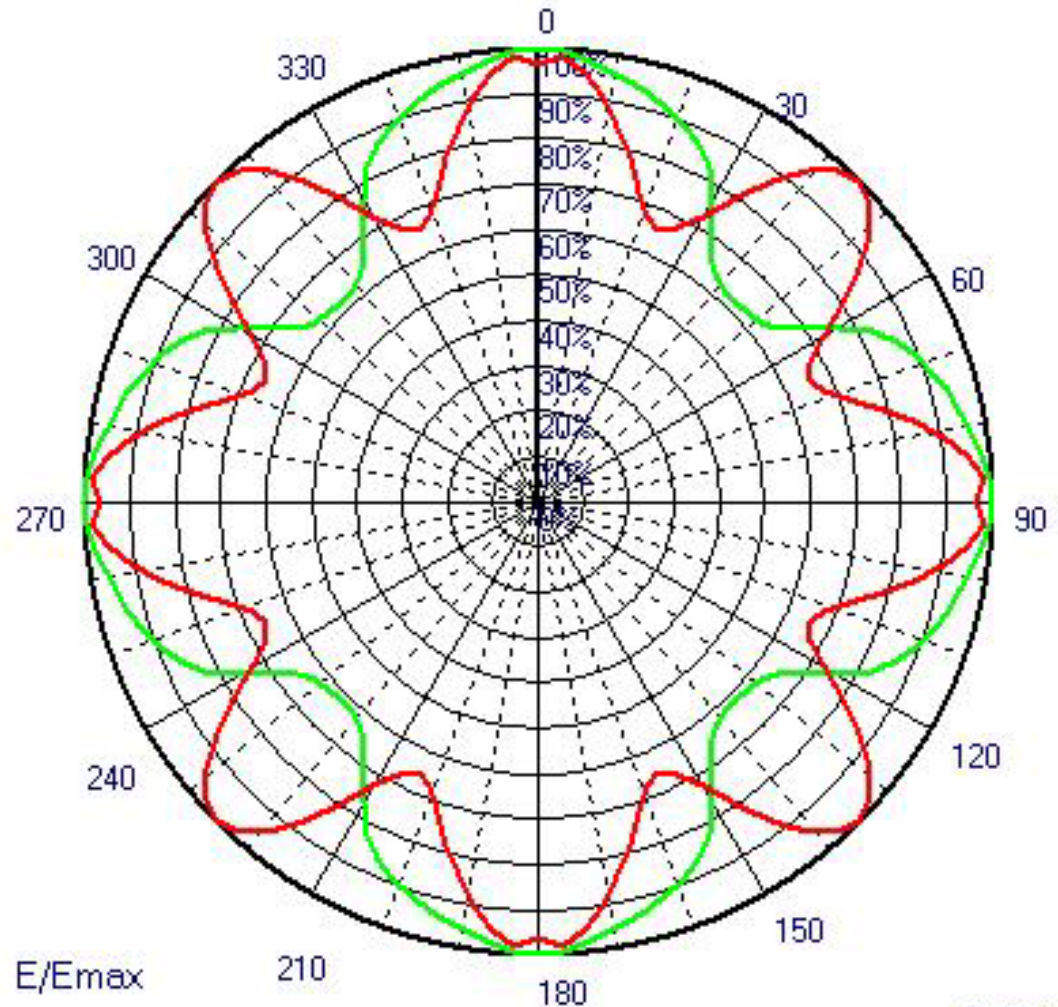

HPOL

- ± 1.8 dB scalloping

VPOL

- ± 1.1 dB scalloping

THANK YOU FOR YOUR INTEREST



RYMSA

These presentations are available at
www.mcibroadcast.com