



UHF MANIFOLD MULTI-CHANNEL COMBINER

- Silver Plated Iris for Optimum Performance
- Inductive Iris Design for High Power
- Wide Passband for each channel/Center frequency
- Input with VSWR tuner
- Low Insertion Loss



Micro Communications, Inc. offers a full range of UHF channel combiners in starpoint or (manifold) configurations. The channels are combined into one antenna feed line.

The number of cavities in any of these combiners is determined by the spacing between the channels within the system. Typically, for most requirements, four bandpass cavities per channel will suffice with a channel spacing of 24 MHz or more. The cavities are designed and constructed to ensure good stability over a wide range of environmental changes.

A variety of layouts are available with overall sizes depending on power levels, number of channels to be combined and other considerations. Construction is usually from rugged aluminum welded flanged cavities within a freestanding aluminum frame. MCI bandpass filters, as always, are precision tuned at the factory to provide optimal reflective and transmissive phase matching, ensuring good in-band VSWR while minimizing insertion losses. In systems where the channel spacings are less than 24MHz, the use of six section bandpass filters are incorporated. Thermally stable filter designs are also available.



SPECIFICATIONS (2 channel spacing)
VSWR : < 1.08:1 Isolation : > 60 dB (channel to channel) Channel Loss : < 0.30 dB @ F_c Group Delay: < +/- 50 ns

SPECIFICATIONS (1 channel spacing)
VSWR: < 1.08:1 Isolation : > 40 dB (channel to channel) Channel Loss: < 0.45 dB @ F_c Group Delay: < +/- 150 ns

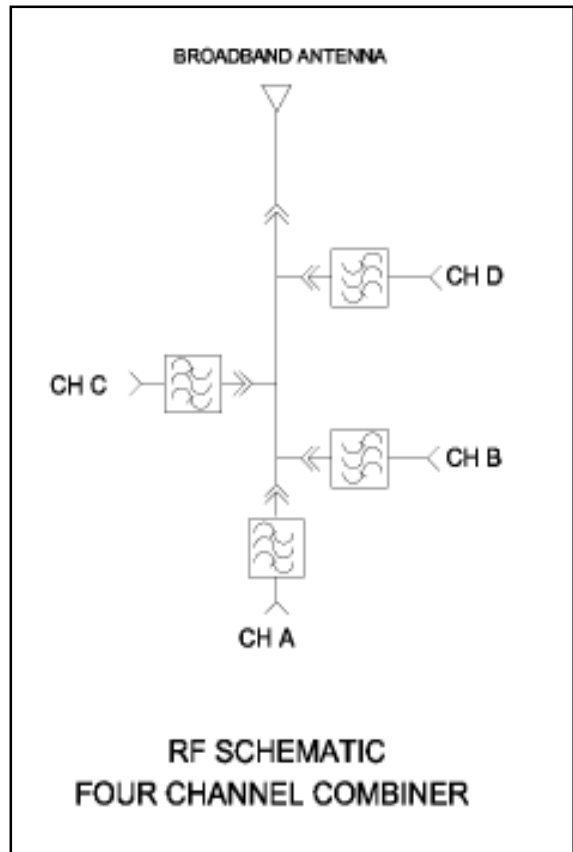

All specifications are subject to change without notice

